

Contract Drawings For

CORDOVA FISH PASSAGE IMPROVEMENT PROJECTS

COPPER RIVER HIGHWAY - MP 18.2

18 MILE CREEK CROSSING - COP 22

U.S. FISH AND WILDLIFE SERVICE

SECTION 30, TOWNSHIP 16 SOUTH, RANGE 1 EAST, COPPER RIVER MERIDIAN, ALASKA
 DECEMBER 2020



PROJECT LOCATION		
ADF&G SITE NO.	CRWP ID	COPPER RIVER HWY MP
20100488	COP 22	18.2

DESIGN DESIGNATIONS	
AADT 2015	244

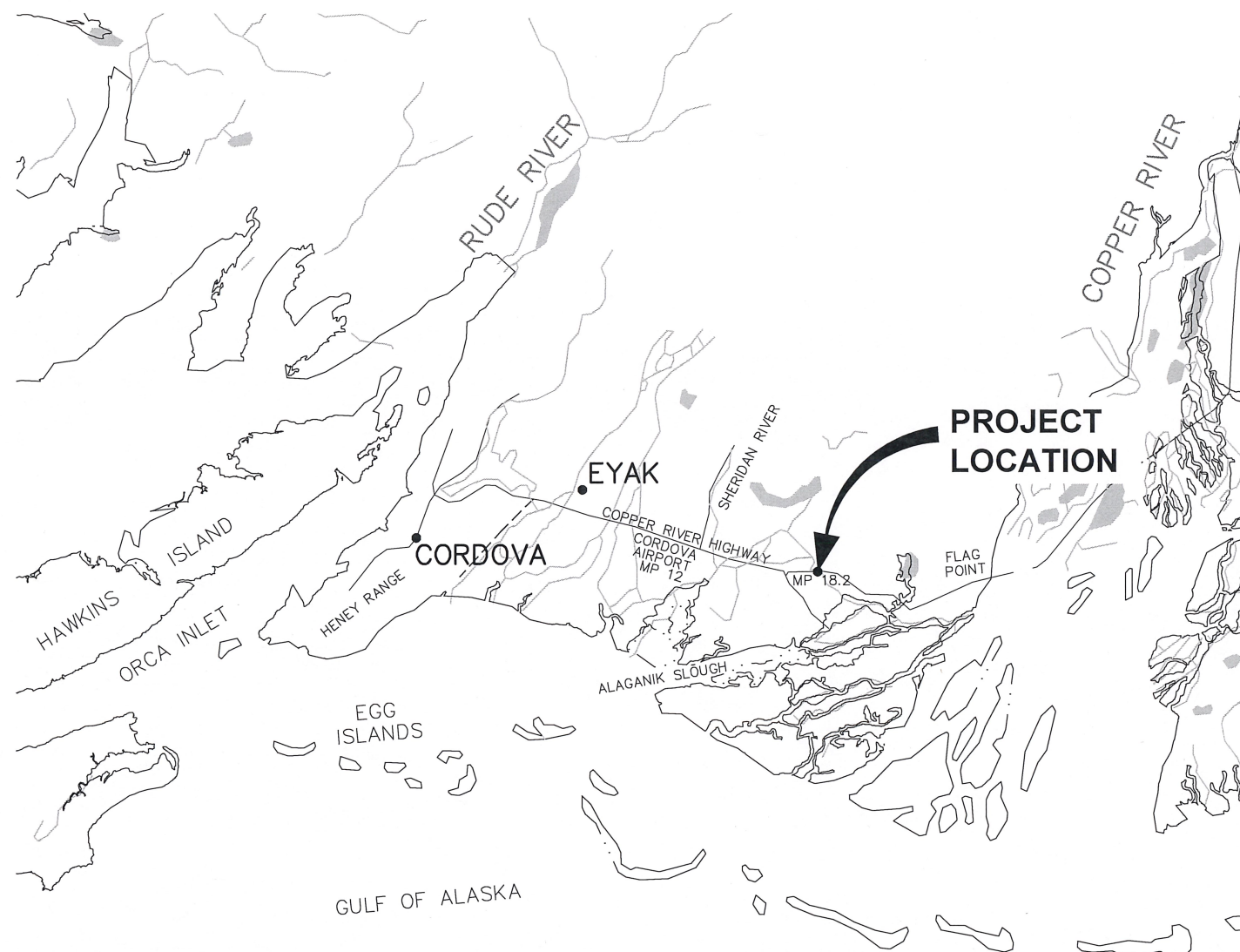

VICINITY MAP
 NTS

DRAWING INDEX

- C1 COVER SHEET
- C2 GENERAL NOTES AND QUANTITIES
- C3 SURVEY CONTROL
- C4 EXISTING STREAM PLAN AND PROFILE
- C5 STREAM PLAN AND PROFILE
- C6 ROADWAY PLAN AND PROFILE
- C7 STREAM DESIGN DETAILS
- C8 STREAM SECTIONS AND DETAILS
- C9 ESCP, STREAM DIVERSION & ROADWAY DIVERSION PLAN
- C10 REVEGETATION PLAN

PREPARED BY: DOWL

C:\Civil_3D\Projects_2018\2018_36\63087-01\Hydrology\SC18-CH-DR-63087-COP-22.dwg PLOT DATE 2020-12-4 14:12 SAVED DATE 2020-12-04 14:05 USER: hrbuck

ESTIMATE OF QUANTITIES

ITEM NO.	ITEM DESCRIPTION	PAY UNIT	QUANTITY
201(9)	CLEARING AND GRUBBING	LUMP SUM	ALL REQUIRED
202(4)	REMOVAL OF CULVERT PIPE	LINEAR FOOT	61
203(3)	UNCLASSIFIED EXCAVATION	CUBIC YARD	1463
203(5A)	BORROW, SELECTED MATERIAL, TYPE A	CUBIC YARD	1287
203(5B)	SUBBASE, GRADING F	CUBIC YARD	528
301(4)	AGGREGATE SURFACE COURSE, GRADING E-1	CUBIC YARD	55
602(2)	STRUCTURAL PLATE ALUMINUM PIPE ARCH, 64" SPAN, 43" RISE	LINEAR FOOT	83
602(4)	STRUCTURAL PLATE ALUMINUM BOX CULVERT, 19'-10" SPAN, 7'-8" RISE	LINEAR FOOT	90
611(1A)	RIPRAP, CLASS I	CUBIC YARD	121
611(1B)	RIPRAP, CLASS II	CUBIC YARD	44
613(2)	CULVERT MARKER POST	EACH	4
618(2)	SEEDING	POUND	3
620(1)	TOPSOIL (4")	SQUARE YARD	240
630(3B)	GEOTEXTILE, REINFORCEMENT, TYPE 2	SQUARE YARD	977
631(2)	GEOTEXTILE, EROSION CONTROL, CLASS 1	SQUARE YARD	84
640(1)	MOBILIZATION AND DEMOBILIZATION	LUMP SUM	ALL REQUIRED
641(3)	TEMPORARY EROSION, SEDIMENT AND POLLUTION CONTROL	LUMP SUM	ALL REQUIRED
642(1)	CONSTRUCTION SURVEYING	LUMP SUM	ALL REQUIRED
642(14)	AS-BUILT PLANS	LUMP SUM	ALL REQUIRED
643(2)	TRAFFIC MAINTENANCE	LUMP SUM	ALL REQUIRED
644(15)	NUCLEAR TESTING EQUIPMENT STORAGE SHED	LUMP SUM	ALL REQUIRED
672(1)	STREAM DIVERSION & DEWATERING	LUMP SUM	ALL REQUIRED
690(10)	WATERWAY BED FILL	LINEAR FOOT	189
690(12)	WATERWAY BANK REVEGETATION AND PROTECTION	LUMP SUM	ALL REQUIRED
690(13)	ROUNDED RIVER ROCK	CUBIC YARD	66

LEGEND

DESCRIPTION
APPROXIMATE RIGHT-OF-WAY
CONTROL POINT
ORDINARY HIGH WATER
EXISTING CULVERT
EDGE OF PAVEMENT
EDGE OF GRAVEL/SHOULDER
EDGE OF VEGETATION
EXISTING THALWEG
TOP OF BANK
TOE OF SLOPE
PROPOSED CULVERT
WATERWAY BED FILL
WATERWAY BANK REVEGETATION AND PROTECTION
RIPRAP
ROUNDED RIVER ROCK
AGGREGATE SURFACE COURSE, E-1
SELECTED MATERIAL, TYPE A
SUBBASE, GRADING F
SEED
BULK BAG COFFERDAM

ABBREVIATIONS

ALCAP	ALUMINUM CAP
AVASP	AS VERTICAL AS SAFELY POSSIBLE
BFW	BANKFULL WIDTH
BOF	BOTTOM OF FOOTING
CFS	CUBIC FEET PER SECOND
CL	CENTERLINE
CMP	CORRUGATED METAL PIPE
CRH	COPPER RIVER HIGHWAY
ELEV	ELEVATION
ESCP	EROSION AND SEDIMENT CONTROL PLAN
HW/D	HEADWATER TO DEPTH RATIO
INV	INVERT ELEVATION
MIN	MINIMUM
MP	MILEPOST
NTS	NOT TO SCALE
OHW	ORDINARY HIGH WATER
OSHA	OCCUPATIONAL SAFETY AND HEALTH ADMINISTRATION
Q	FLOW
ROW	RIGHT-OF-WAY
STA	STATION
TYP	TYPICAL
VAP	VERTICAL ADJUSTMENT POTENTIAL

TABLE 1

COARSE MATERIAL: RIPRAP, CLASS I		
APPROX. SIZE	MASS (LBS)	% PASSING
10"	50	100
8"	25	50

TABLE 2

FINE MATERIAL: POROUS BACKFILL	
SIZE/SIEVE	% PASSING
3"	100
1"	65
0.75"	50
#4	25
#10	15

GENERAL NOTES

1. THE CONTRACTOR IS RESPONSIBLE FOR DETERMINING THE EXACT LOCATION OF ALL SITE FEATURES. IF THE CONTRACTOR DISCOVERS CONDITIONS OTHER THAN THOSE SHOWN ON THE PLANS, CONTRACTOR SHALL IMMEDIATELY NOTIFY THE OWNER'S REPRESENTATIVE.
2. COORDINATE CONSTRUCTION STAGING AND MOBILIZATION AREAS AND ACTIVITIES WITH OWNER'S REPRESENTATIVE.
3. COORDINATE WITH OTHER CONTRACTORS WHO MAY BE PRESENT.
4. EXERCISE CAUTION AND COMPLY WITH ALL APPLICABLE OSHA REQUIREMENTS FOR WORKING IN CONFINED AREAS.
5. STATIONING IS ALONG CENTERLINE OF STREAM OR ROADWAY.
6. VERIFY ELEVATIONS OF ALL PROPOSED STRUCTURES PRIOR TO CONSTRUCTION. REPORT ANY DISCREPANCIES FROM PLANS IMMEDIATELY TO OWNER'S REPRESENTATIVE.
7. CULVERT DESIGN LOAD: AASHTO LOADING HL-93, MINIMUM SOIL BEARING CAPACITY: 3,900 PSF.
8. EXCAVATION AND COMPACTION:
 - A. REMOVE AND DISPOSE OF ALL ORGANIC OR OVER SATURATED SOFT MATERIAL, WHICH CANNOT BE COMPACTED.
 - B. BACKFILL SHALL BE PLACED AND COMPACTED WITH CARE AND SHALL BE BROUGHT UP EVENLY AND SIMULTANEOUSLY ON BOTH SIDES OF PIPE. MATERIAL TO BE COMPACTED TO 95% MAXIMUM DENSITY.
9. CULVERT INSTALLATION:
 - A. CULVERT JOINTS SHALL NOT LEAK.
 - B. CULVERT INFILL MATERIAL SHALL BE INSTALLED IN PIPE ACCORDING TO PLANS. MANUAL INSTALLATION IS REQUIRED.
10. ALL VEGETATION IN THE AREAS NOT AFFECTED BY WORK SHALL BE PRESERVED AND PROTECTED BY THE CONTRACTOR. RESEED ALL DISTURBED AREAS.
11. TWO CULVERT MARKERS WILL BE INSTALLED AT EACH CULVERT PER STD D-09.00.

TABLE 3

WATERWAY BED FILL	
SIZE/SIEVE	% PASSING
12"	100
9"	85
6"	58
3"	49
1"	32
0.75"	23
#4	10
#10	6

TABLE 4

ROUNDED RIVER ROCK	
SIZE/SIEVE	% PASSING
12"	100
9"	75
6"	30
3"	15
1"	10
0.75"	5
#4	0
#10	0

THE FOLLOWING DOT&PF STANDARD DRAWING APPLIES TO THIS PROJECT:
D-09.00 CULVERT MARKER POST

REV	DATE	DESCRIPTION	BY

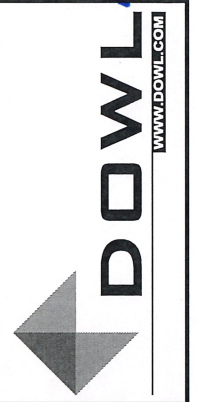

CORDOVA FISH PASSAGE IMPROVEMENTS
MIDDLE FORK 18 MILE CREEK - COP 22
GENERAL NOTES AND QUANTITIES
CORDOVA, ALASKA

PROJECT 1136.63087.01
DATE DECEMBER 2020

© DOWL 2020
SHEET
C2 OF C10

C:\Civil_3D\Projects_2018\2018\36\63087-01\Survey\Mc-VB-BA-63087-COP22.dwg PLOT DATE 2020-12-04 09:31 SAVED DATE 2020-12-03 16:06 USER: hrbuck

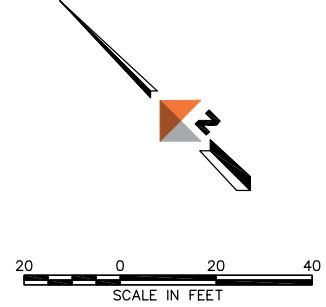
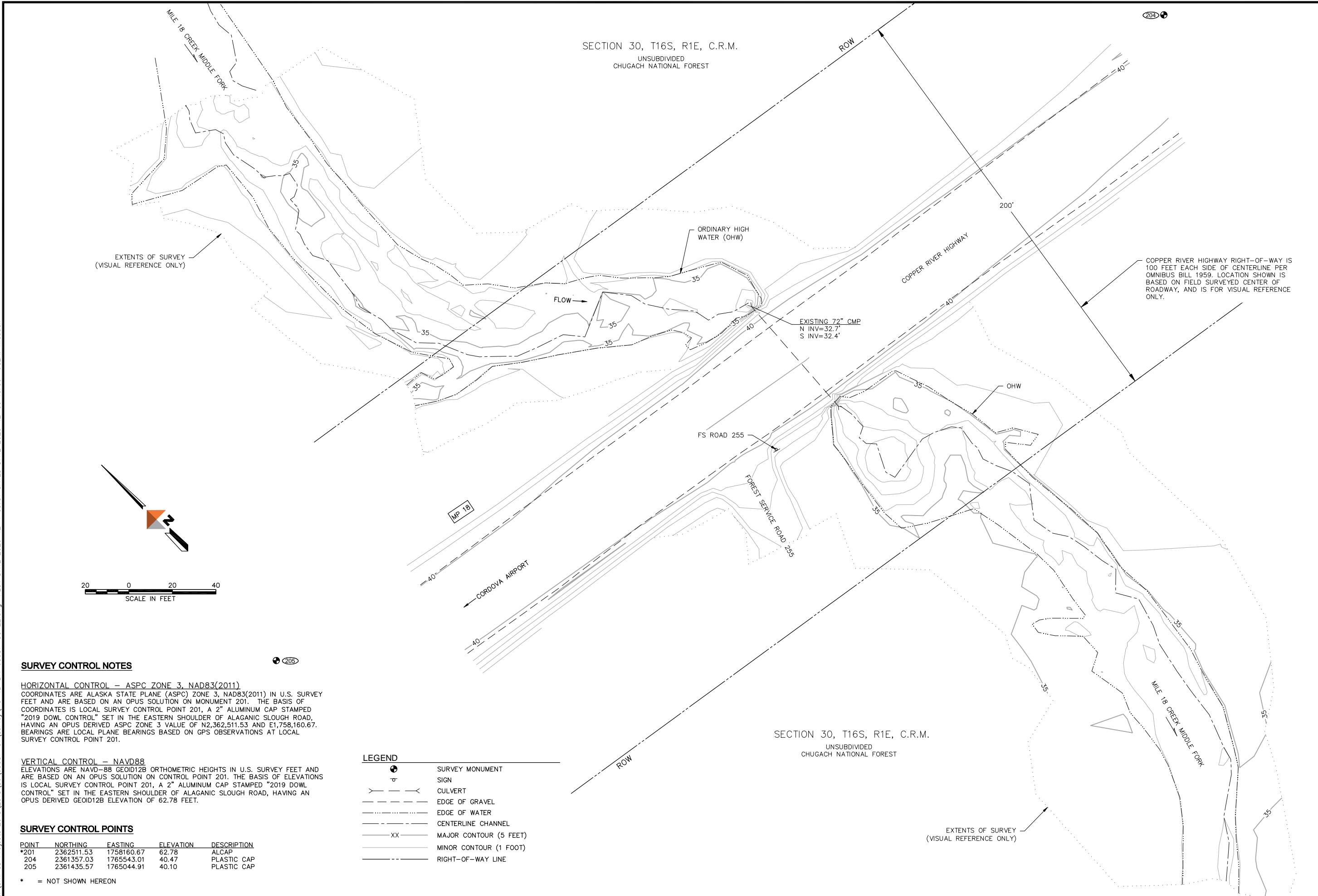

SURVEY CONTROL NOTES

HORIZONTAL CONTROL - ASPC_ZONE_3_NAD83(2011)
 COORDINATES ARE ALASKA STATE PLANE (ASPC) ZONE 3, NAD83(2011) IN U.S. SURVEY FEET AND ARE BASED ON AN OPUS SOLUTION ON MONUMENT 201. THE BASIS OF COORDINATES IS LOCAL SURVEY CONTROL POINT 201, A 2" ALUMINUM CAP STAMPED "2019 DOWL CONTROL" SET IN THE EASTERN SHOULDER OF ALAGANIC SLOUGH ROAD, HAVING AN OPUS DERIVED ASPC ZONE 3 VALUE OF N2,362,511.53 AND E1,758,160.67. BEARINGS ARE LOCAL PLANE BEARINGS BASED ON GPS OBSERVATIONS AT LOCAL SURVEY CONTROL POINT 201.

VERTICAL CONTROL - NAVD88
 ELEVATIONS ARE NAVD-88 GEOID12B ORTHOMETRIC HEIGHTS IN U.S. SURVEY FEET AND ARE BASED ON AN OPUS SOLUTION ON CONTROL POINT 201. THE BASIS OF ELEVATIONS IS LOCAL SURVEY CONTROL POINT 201, A 2" ALUMINUM CAP STAMPED "2019 DOWL CONTROL" SET IN THE EASTERN SHOULDER OF ALAGANIC SLOUGH ROAD, HAVING AN OPUS DERIVED GEOID12B ELEVATION OF 62.78 FEET.

SURVEY CONTROL POINTS

POINT	NORTHING	EASTING	ELEVATION	DESCRIPTION
*201	2362511.53	1758160.67	62.78	ALCAP
204	2361357.03	1765543.01	40.47	PLASTIC CAP
205	2361435.57	1765044.91	40.10	PLASTIC CAP

* = NOT SHOWN HEREON

LEGEND

- SURVEY MONUMENT
- SIGN
- CULVERT
- EDGE OF GRAVEL
- EDGE OF WATER
- CENTERLINE CHANNEL
- MAJOR CONTOUR (5 FEET)
- MINOR CONTOUR (1 FOOT)
- RIGHT-OF-WAY LINE

REV	DATE	DESCRIPTION	BY

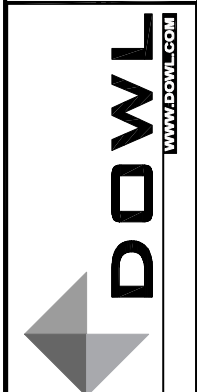

CORDOVA FISH PASSAGE IMPROVEMENTS
 MIDDLE FORK 18 MILE CREEK - COP 22
 SURVEY CONTROL
 SECTION 30, T16S, R1E, C.R.M. ALASKA
 CORDOVA RECORDING DISTRICT, ALASKA

PROJECT 1136.63087.01
 DATE DECEMBER 2020

© DOWL 2020
 SHEET

C3 OF C10

C:\Civil_3D_Projects_2018\2018\36\63087-01\Hydrology\SCIB-CH-DR-63087-COP-22.dwg PLOT DATE 2020-12-04 13:37 SAVED DATE 2020-12-03 15:21 USER: hrbuck

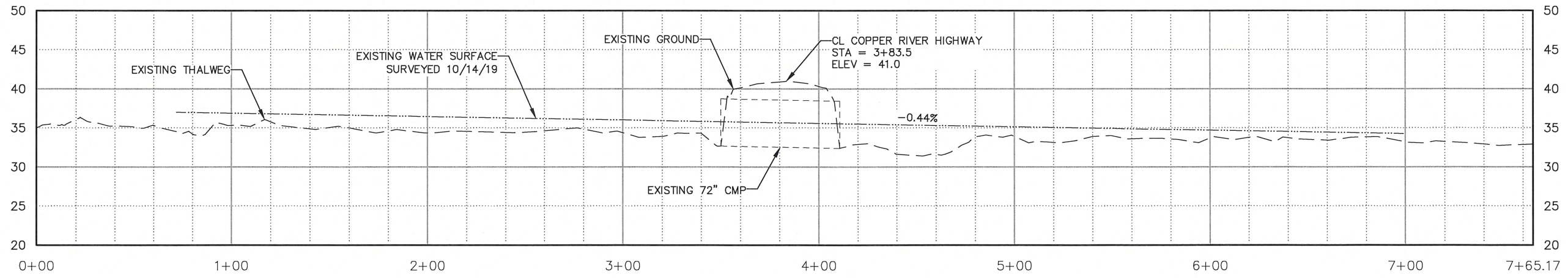
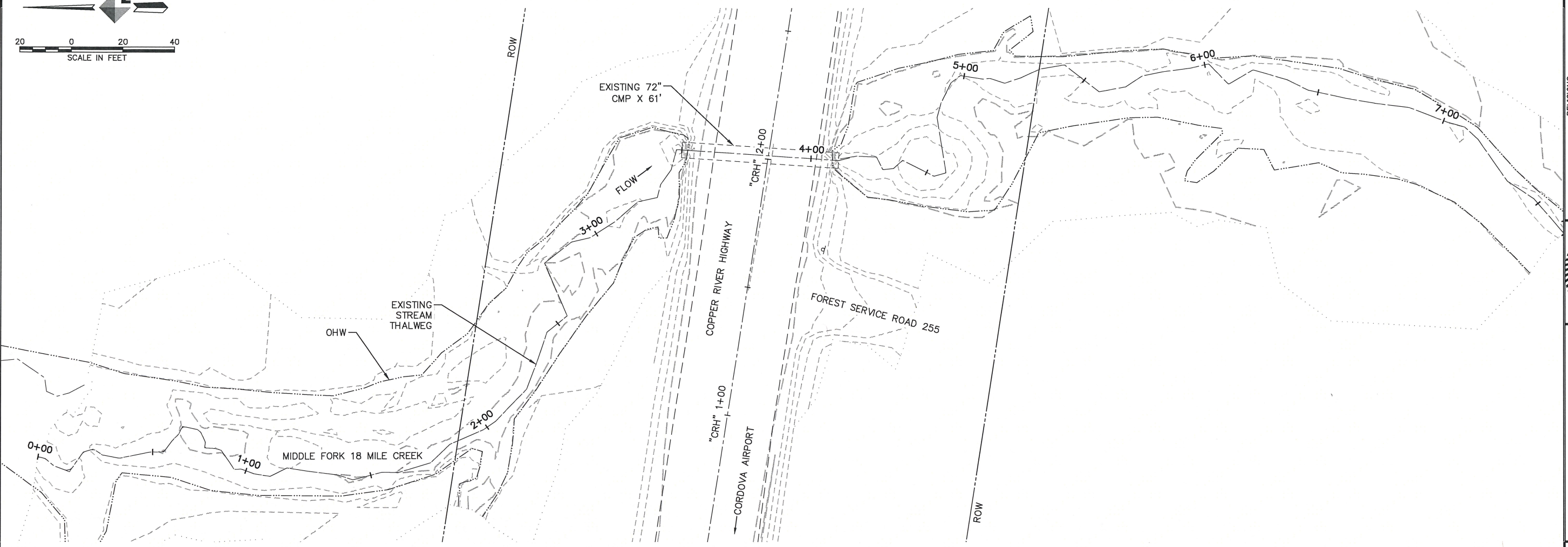
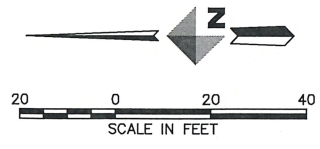

REV	DATE	DESCRIPTION	BY

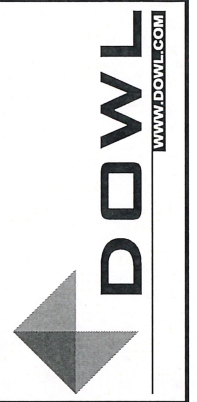

CORDOVA FISH PASSAGE IMPROVEMENTS
MIDDLE FORK 18 MILE CREEK - COP 22
EXISTING STREAM PLAN AND PROFILE
CORDOVA, ALASKA

PROJECT 1136.63087.01
DATE DECEMBER 2020

© DOWL 2020
SHEET

C4 OF C10

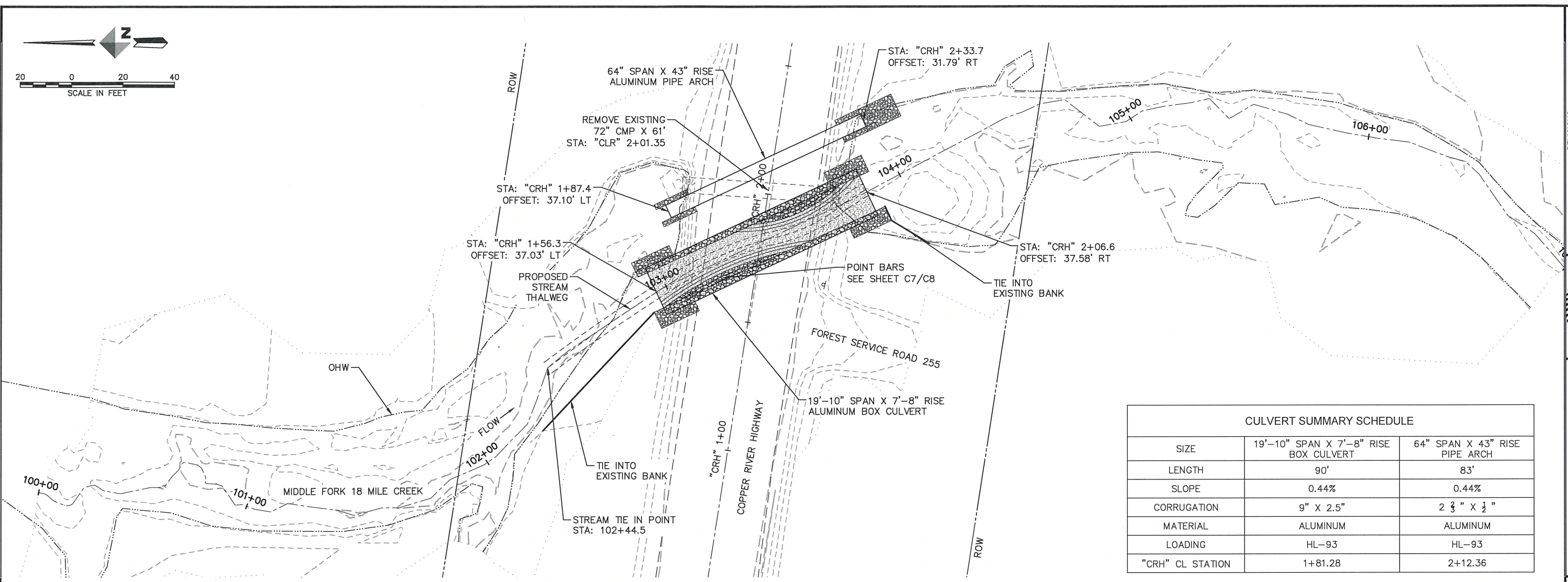
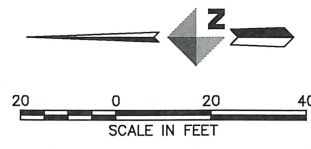

CULVERT SUMMARY SCHEDULE		
SIZE	19'-10" SPAN X 7'-8" RISE BOX CULVERT	64" SPAN X 43" RISE PIPE ARCH
LENGTH	90'	83'
SLOPE	0.44%	0.44%
CORRUGATION	9" X 2.5"	2 3/4" X 1/2"
MATERIAL	ALUMINUM	ALUMINUM
LOADING	HL-93	HL-93
"CRH" CL STATION	1+81.28	2+12.36

CULVERT COORDINATE TABLE				
SIZE	POINT	NORTHING	EASTING	ELEVATION
19'-10" SPAN X 7'-8" RISE BOX CULVERT	INLET INV.	2361406.48	1765273.25	31.45
	OUTLET INV.	2361324.96	1765311.39	31.05
64" SPAN X 43" RISE PIPE ARCH	INLET INV.	2361401.70	1765304.01	34.59
	OUTLET INV.	2361326.47	1765339.07	34.22

HYDROLOGIC & HYDRAULIC SUMMARY					
EXCEEDANCE PROBABILITY	RETURN PERIOD (YEAR)	DESIGN DISCHARGE (CFS)	DESIGN HIGH WATER ELEVATION (FT)	REGULATORY FLOOD	HW/D
50%	2	319	37.80	N/A	0.74
2%	50	413	38.48	N/A	0.87
1%	100	427	38.57	N/A	0.89
DRAINAGE AREA = 1.9 SQUARE MILES					
ANTICIPATED ADDITIONAL BACKWATER = 0 FEET					
ROADWAY OVERTOPPING Q = 598.34 CFS					

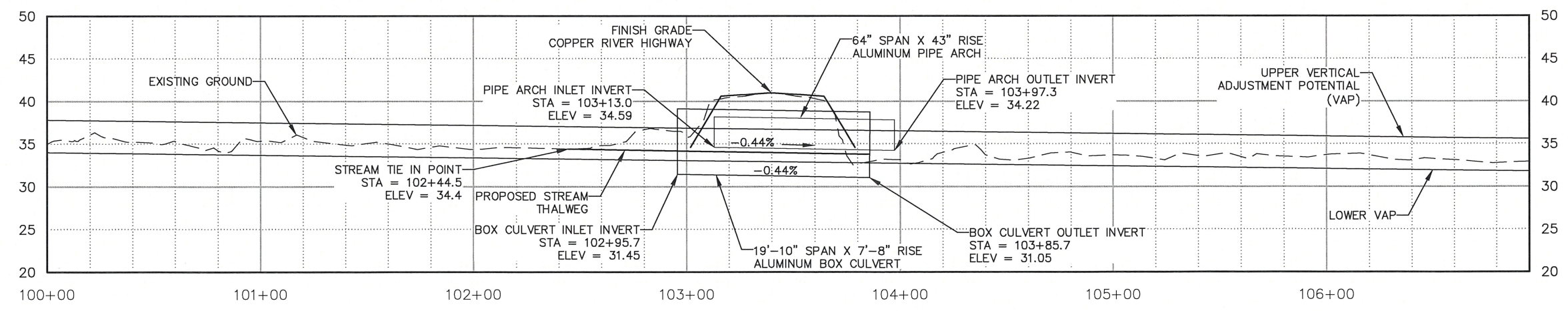

REV	DATE	DESCRIPTION	BY



CORDOVA FISH PASSAGE IMPROVEMENTS
 MIDDLE FORK 18 MILE CREEK - COP 22
 STREAM PLAN AND PROFILE
 CORDOVA, ALASKA

PROJECT 1136.63087.01
 DATE DECEMBER 2020

DOWL 2020
 SHEET

C5 OF C10

C:\Civil 3D Projects 2018\2018\36\63087-01\Hydrology\SC18-CH-DR-63087-COP-22.dwg PLOT DATE 2020-12-03 15:21 USER: hrbuck

C:\Civil_3D\Projects_2018\2018\36\63087-01\Hydrology\SC18-CH-DR-63087-COP-22.dwg PLOT DATE 2020-12-04 13:39 SAVED DATE 2020-12-03 15:21 USER: hrbuck

205

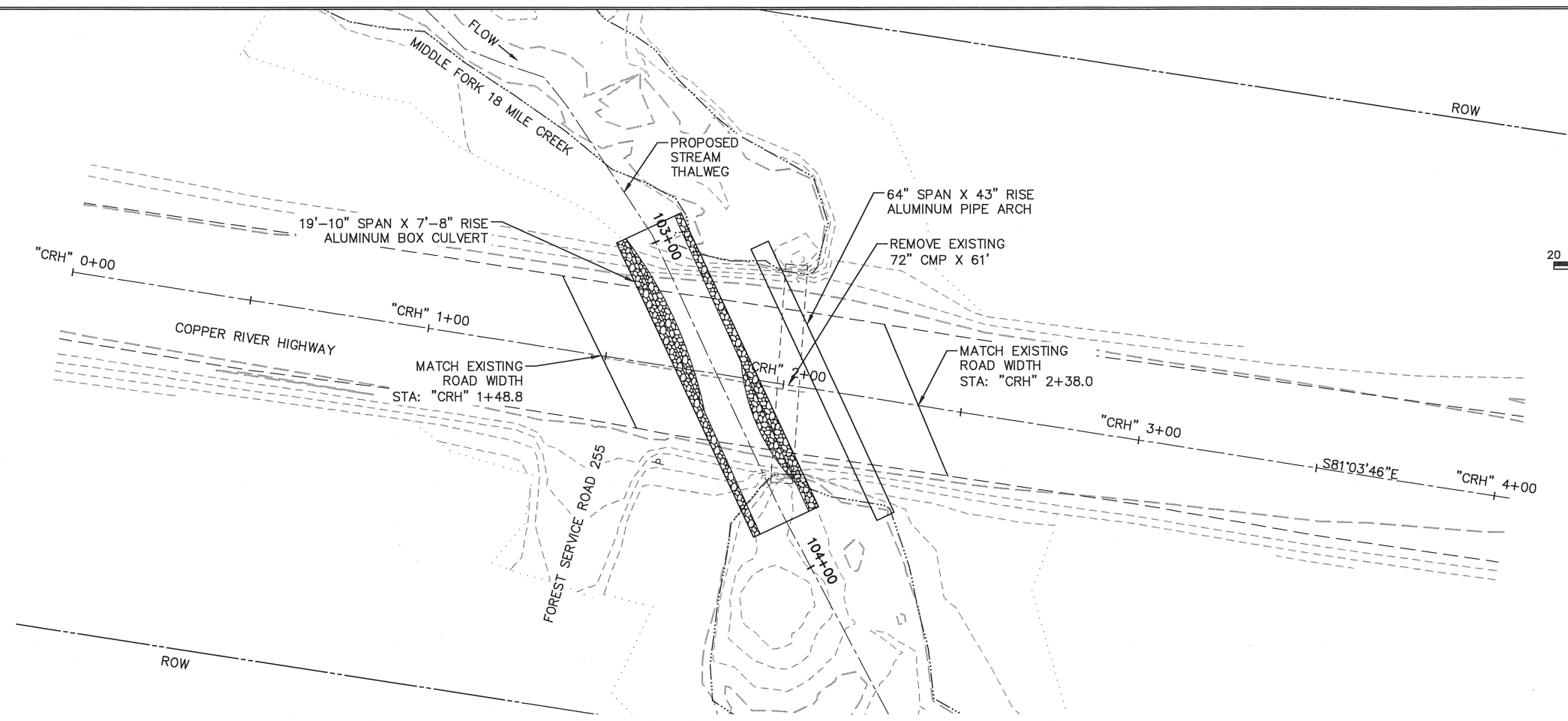

REV	DATE	DESCRIPTION	BY

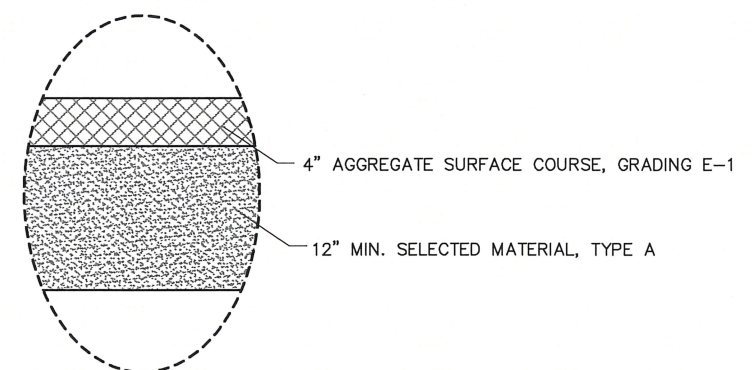
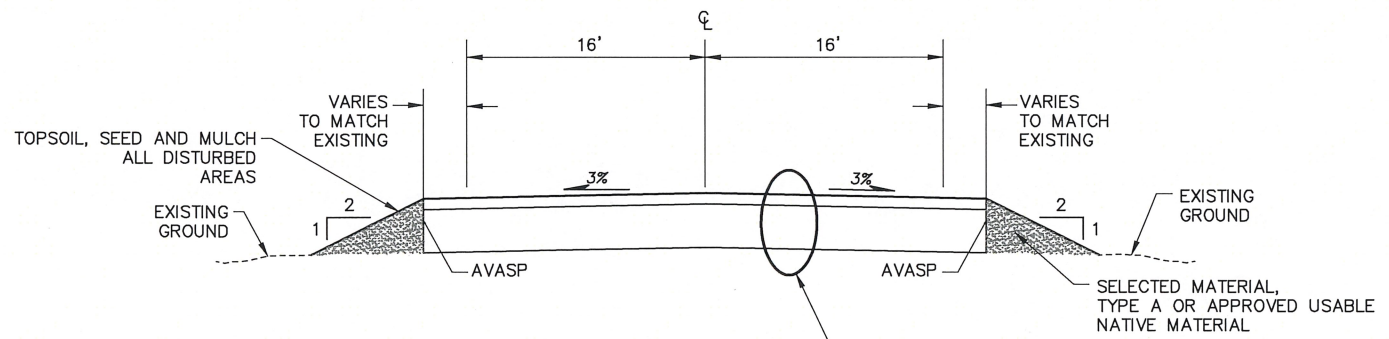
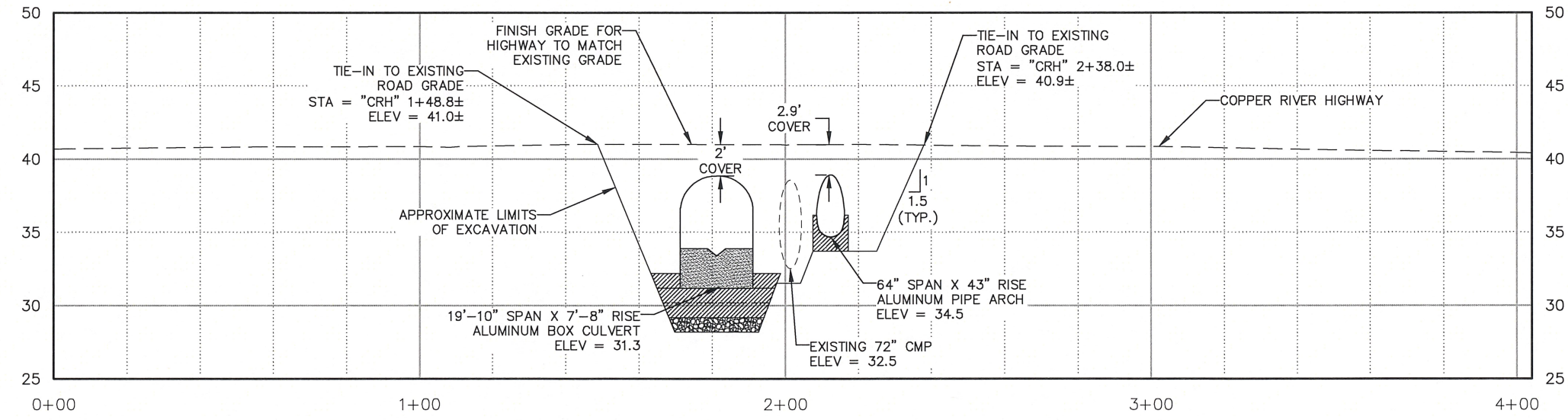
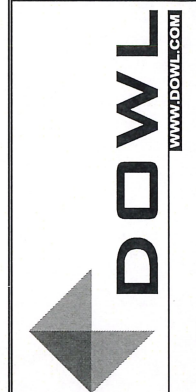

1 ROADWAY SECTION
C6 NTS

2 ROADWAY STRUCTURAL SECTION
C6 NTS

CORDOVA FISH PASSAGE IMPROVEMENTS
MIDDLE FORK 18 MILE CREEK - COP 22
ROADWAY PLAN AND PROFILE
CORDOVA, ALASKA

PROJECT 1136.63087.01
DATE DECEMBER 2020

© DOWL 2020
SHEET

C6 OF C10

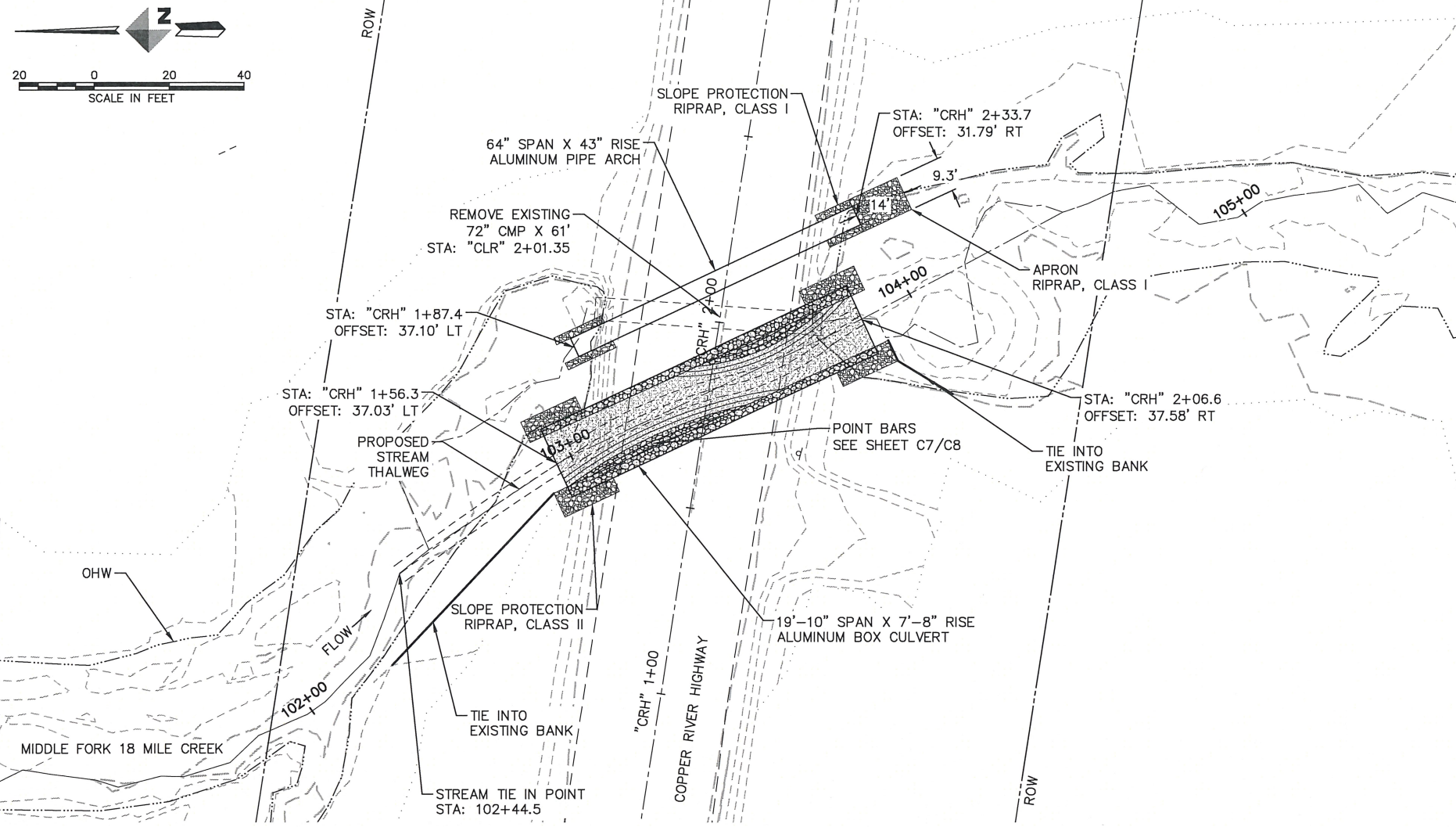

1
C7
STREAM SIMULATION DETAIL - PLAN VIEW

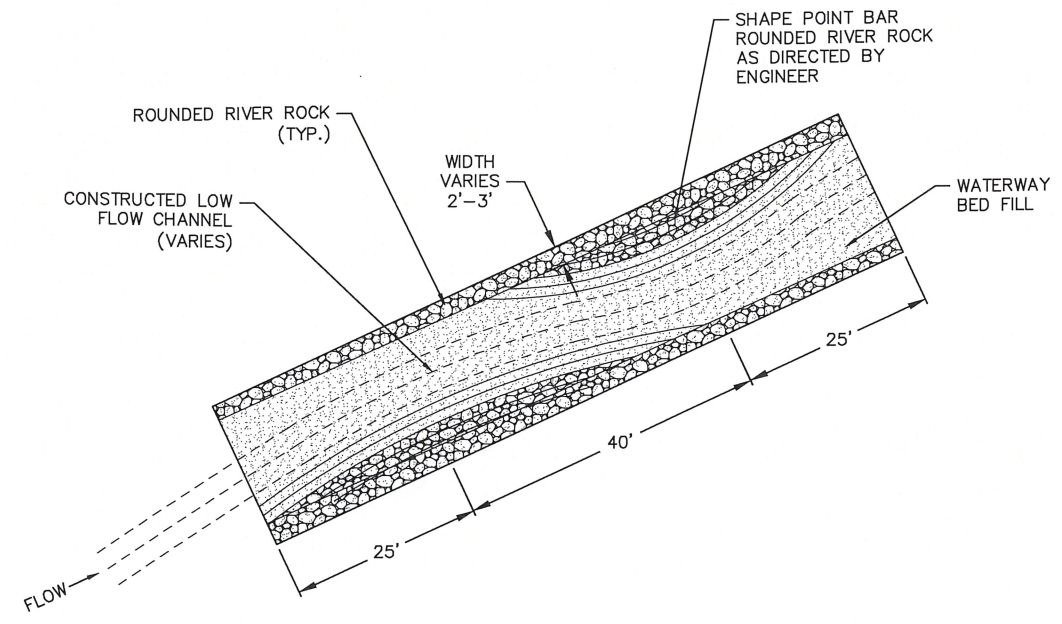

2
C7
CULVERT STREAM DETAIL
NTS

C:\Civil 3D Projects 2018\2018\36\63087-01\Hydrology\SC18-CH-DR-63087-COP-22.dwg PLOT DATE 2020-12-04 13:39 SAVED DATE 2020-12-03 15:21 USER: hrbuck

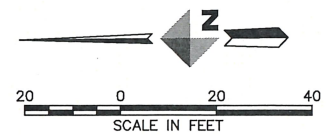

REV	DATE	DESCRIPTION	BY

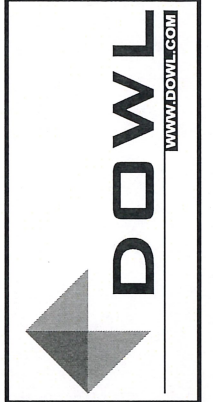

CORDOVA FISH PASSAGE IMPROVEMENTS
MIDDLE FORK 18 MILE CREEK - COP 22
STREAM DESIGN DETAILS
CORDOVA, ALASKA

PROJECT 1136.63087.01
DATE DECEMBER 2020

© DOWL 2020
SHEET

C7 OF C10

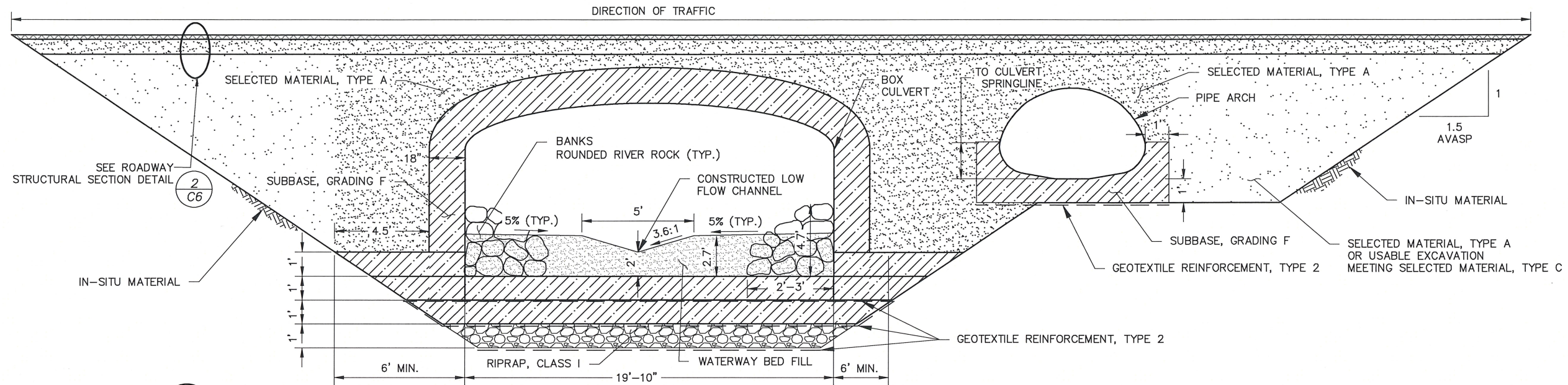

1
C8
TYPICAL CULVERT SECTION
NTS

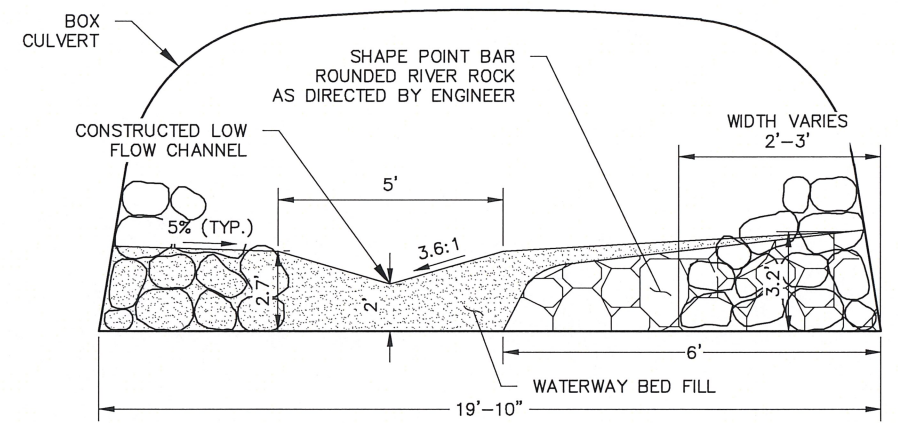

2
C8
TYPICAL CULVERT SECTION AT ROCK CLUSTERS
NTS

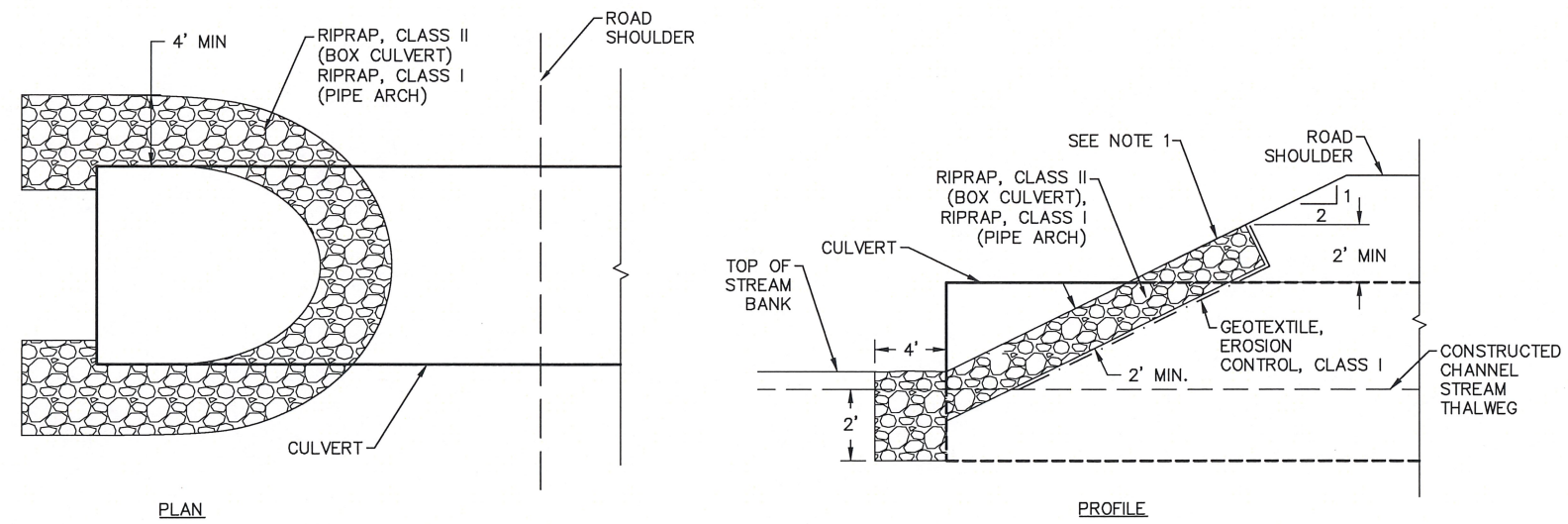

3
C8
RIPRAP SLOPE PROTECTION SECTION
NTS

- NOTES:
1. FILL VOIDS IN RIPRAP WITH SELECTED MATERIAL, TYPE A OR USABLE EXCAVATION MEETING SELECTED MATERIAL, TYPE C AND PLACE SALVAGED ORGANIC TOPSOIL AND SEED.

- NOTES:
1. GEOTEXTILE REINFORCEMENT, TYPE 2 SHALL BE PLACED BETWEEN IN-SITU MATERIAL AND RIPRAP, CLASS I, PLACED BETWEEN RIPRAP, CLASS I AND SUBBASE, GRADING F, AND PLACED BETWEEN EACH ONE-FOOT LAYER OF SUBBASE, GRADING F.
 2. FILL VOIDS IN RIPRAP. MIX RIPRAP WITH FINES PRIOR TO PLACEMENT AND WASH FINES IN AFTER PLACEMENT.

REV	DATE	DESCRIPTION	BY

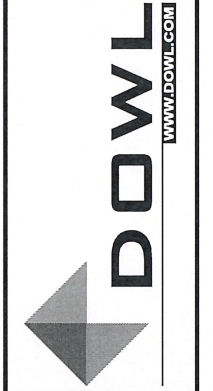

CORDOVA FISH PASSAGE IMPROVEMENTS
MIDDLE FORK 18 MILE CREEK - COP 22
STREAM SECTIONS AND DETAILS

PROJECT 1136.63087.01
DATE DECEMBER 2020

© DOWL 2020
SHEET

C8 OF C10

C:\Civil_3D\Projects_2018\2018\36\Hydrology\Sci18-CH-DR-63087-COP-22.dwg PLOT DATE 2020-12-04 13:39 SAVED DATE 2020-12-03 15:21 USER: hrbuck

ROADWAY DIVERSION NOTES:

REFER TO SPECIFICATIONS FOR ROAD CLOSURE AND TRAFFIC CONTROL INFORMATION.

STREAM DIVERSION NOTES:

DUE TO PERMISSIVITY OF GRAVELS IN THE 18 MILE AREA, A COFFERDAM MADE OF SHEET PILE MAY BE NEEDED TO REDUCE GROUNDWATER FLOW INTO EXCAVATED AREA. TEMPORARY DIKES OR BERMS MAY BE USED TO ISOLATE THE WORK AREA FROM WATERS OF THE SURROUNDING AREA. THIS WORK MAY REQUIRE A DIVERSION OF STREAM WATER. THE DESIGNERS RECOGNIZE THAT DIFFERENT CONTRACTORS WILL HAVE VARIOUS APPROACHES FOR CONTROLLING WATER AND CONSTRUCTION SEQUENCING. THIS DIVERSION PLAN HAS BEEN DEVELOPED TO CHECK FOR CONSTRUCTABILITY AND AS A STARTING POINT FOR A CONTRACTOR-GENERATED PLAN. CONTRACTOR MUST SUBMIT DIVERSION PLANS TO ENGINEER FOR APPROVAL PRIOR TO IMPLEMENTATION.

DIVERSION PLAN:

1. PLACE BARRICADES, SIGNS, AND TEMPORARY ROAD DETOUR IN COMPLIANCE WITH SPECIFICATIONS, ADOT&PF, AND MUTCD. COORDINATE WITH OTHER CONTRACTORS WHO MAY BE PRESENT.
2. CONSTRUCT VISQUEEN LINED DIVERSION CHANNEL EAST OF THE EXISTING CROSSING LOCATION.
3. ONE 60" MINIMUM DIAMETER CULVERT CAN BE USED IN DIVERSION CHANNEL TO PROVIDE VEHICULAR ACCESS. CONSTRUCT DIVERSION CHANNEL BANKS TO BE MINIMUM 1' HIGHER THAN THE TOP OF THE DIVERSION PIPE, IF USED.
4. USE BULK BAGS (SUPERSACKS) TO DIVERT STREAM FLOW THROUGH DIVERSION CHANNEL. LOCATION OF DIVERSION CHANNEL IS APPROXIMATE AND SUBJECT TO SITE CONDITIONS.
5. EXCAVATE ROADWAY TO REMOVE EXISTING 72" CULVERT.
6. CONSTRUCT THE NEW ALUMINUM BOX CULVERT AND ALUMINUM PIPE ARCH OVERFLOW CULVERT.
7. INFILL CULVERT AND RECONSTRUCT CREEK CHANNEL AS SHOWN IN PLANS.
8. DIVERT CREEK FLOW THROUGH THE NEW ALUMINUM BOX CULVERT.
9. FILL DIVERSION CHANNEL.
10. RECONSTRUCT CREEK CHANNEL AND BANKS AS SHOWN IN PLANS.
11. RECONSTRUCT COPPER RIVER HIGHWAY OVER THE NEWLY INSTALLED CULVERTS.
12. STABILIZE AND REVEGETATE ALL REMAINING DISTURBED AREAS.
13. RETURN VEHICULAR TRAFFIC TO COPPER RIVER HIGHWAY.

ESCP AND DEWATERING NOTES:

1. DEWATER TRENCH AND WORK AREA WITH PUMP HOSE IF REQUIRED.
2. ALL DISCHARGE POINTS REQUIRE PERMANENT OR TEMPORARY VELOCITY CONTROLS.
3. PROVIDE FOR SEDIMENT REMOVAL FOR ALL DEWATERING ACTIVITY PRIOR TO DISCHARGE FROM THE PROJECT INTO ANY WATER OF THE U.S.
4. PROVIDE SPARE (EXTRA) PUMPS FOR BOTH THE STREAM BYPASS PUMP AND DETWATERING PUMP.
5. EXISTING RIPARIAN VEGETATION SHOULD BE PROTECTED TO MINIMIZE DISTURBANCE.
6. SILT FENCING TO BE USED TO PREVENT DISTURBED SEDIMENT FROM ENTERING THE WATERBODY. ADJUST LOCATION AS NECESSARY AND AS DIRECTED BY THE ENGINEER DURING CONSTRUCTION.
7. EROSION AND SEDIMENT CONTROL DEVICES SHALL BE INSPECTED AND MAINTAINED ON A DAILY BASIS. MAINTENANCE SHALL INCLUDE REMOVAL AND DISPOSAL OF ACCUMULATED SEDIMENT, CLEANING AND REPAIR OF DAMAGED SEDIMENT CONTROL DEVICES.
8. ALL DISTURBED GROUND CAPABLE OF SUPPORTING VEGETATION SHALL BE REVEGETATED FOR FINAL STABILIZATION. ALL AREAS NOT REVEGETATED SHALL BE 100% COVERED BY ROCK OR OTHER PERMANENT NON-ERODIBLE MATERIAL. FINAL STABILIZATION SHALL BE AS APPROVED BY THE ENGINEER.

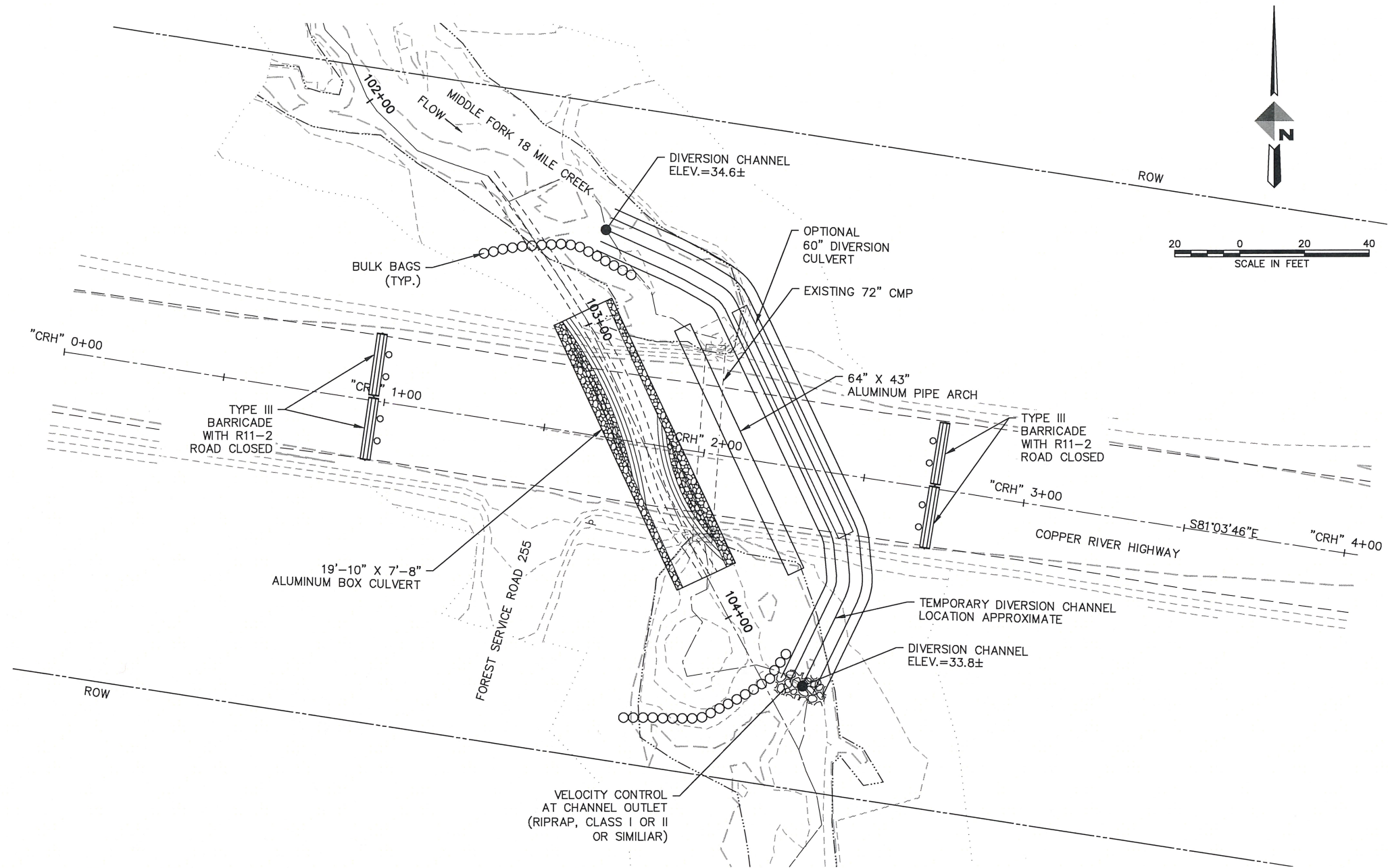

1 ESCP, STREAM DIVERSION & ROADWAY DIVERSION PLAN

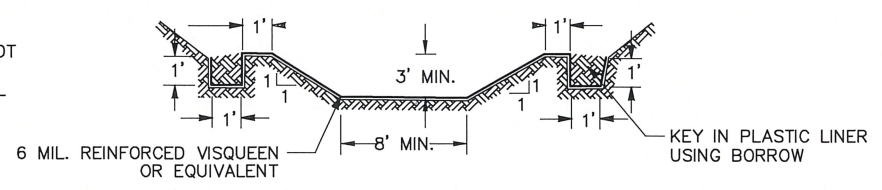

2 DIVERSION CHANNEL
NTS

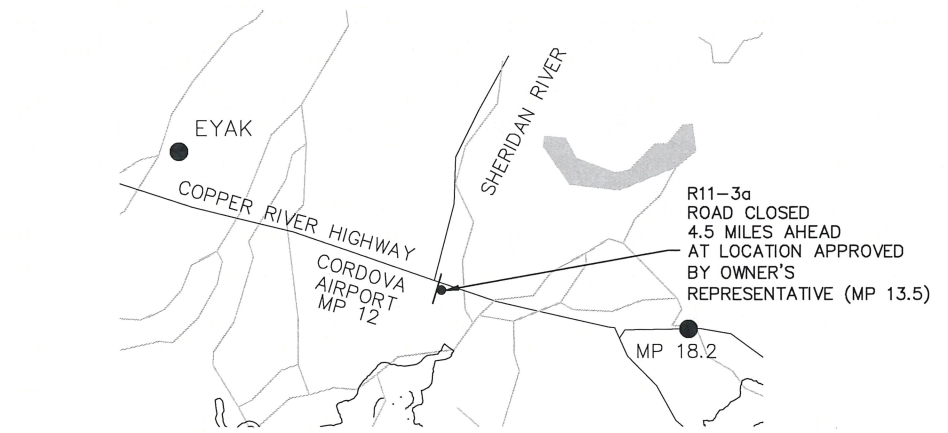

3 ROADWAY DIVERSION SIGNS
NTS

REV	DATE	DESCRIPTION	BY

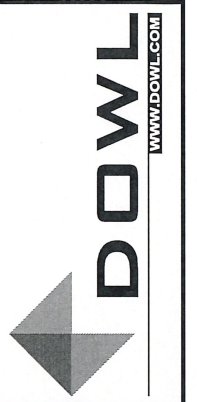

CORDOVA FISH PASSAGE IMPROVEMENTS
MIDDLE FORK 18 MILE CREEK - COP 22
ESCP, STREAM DIVERSION & ROADWAY
DIVERSION PLAN
CORDOVA, ALASKA

PROJECT 1136.63087.01
DATE DECEMBER 2020

DOWL 2020
SHEET

C9 OF C10

C:\Civil 3D Projects\2018\2018_36\63087-01\Hydrology\SC18-CH-DR-63087-COP-22.dwg PLOT DATE 2020-12-04 13:40 SAVED DATE 2020-12-03 15:21 USER: hrobuck

C:\Civil_3D\Projects\2018\2018_36\63087-01\Hydrology\SC18-CH-DR-63087-COP-22.dwg PLOT DATE 2020-12-4 13:40 SAVED DATE 2020-12-03 15:21 USER: hrebuck

NOTES:

1. VEGETATIVE MAT SHALL BE PLACED ON ALL DISTURBED AREAS OUTSIDE OF THE EMBANKMENT SLOPES.
2. SALVAGED VEGETATIVE MAT MUST HAVE A MINIMUM THICKNESS OF 12 INCHES AND BE SOURCED FROM THE DISTURBED AREA OR LOCAL AREA AS DIRECTED BY THE ENGINEER.

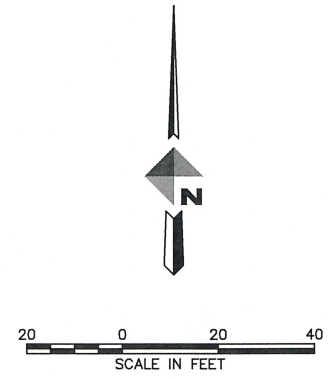

REV	DATE	DESCRIPTION	BY

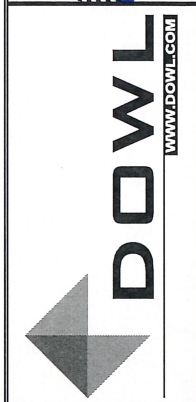

CORDOVA FISH PASSAGE IMPROVEMENTS
MIDDLE FORK 18 MILE CREEK – COP 22
REVEGETATION PLAN

PROJECT 1136.63087.01
DATE DECEMBER 2020
© DOWL 2020
SHEET
C10 OF C10

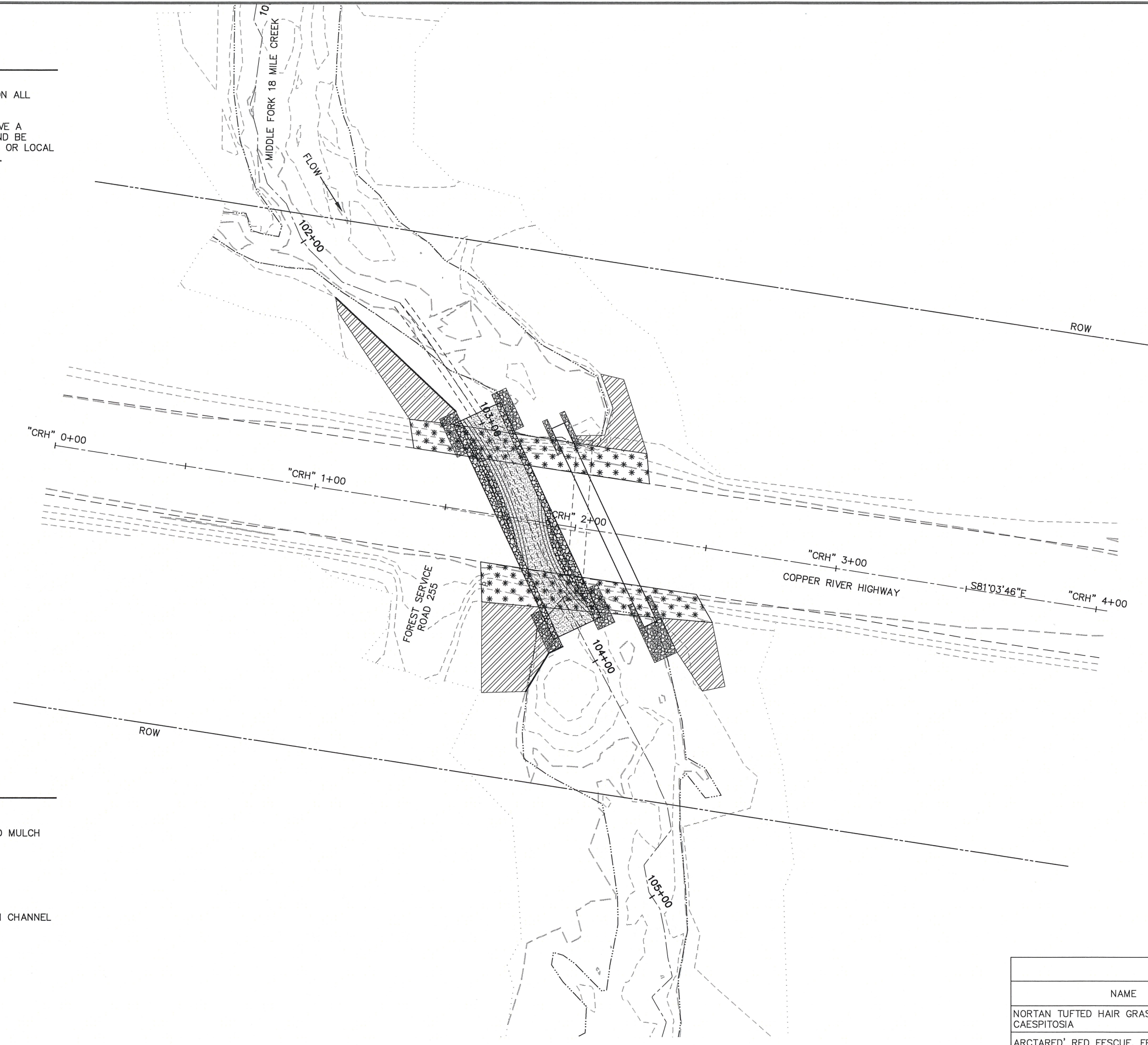

SITE REVEGETATION

- SEED, FERTILIZER, AND MULCH
- VEGETATIVE MAT
- CONSTRUCTED STREAM CHANNEL WATERWAY BED FILL
- RIPRAP
- ROUNDED RIVER ROCK

SEED	
NAME	PROPORTION BY WEIGHT
NORTAN TUFTED HAIR GRASS, DESCHAMPISA CAESPITOSIA	20%
ARCTARED' RED FESCUE, FESTUCA RUBRA	60%
CALAMANGROTIS CANADENSIS	20%

1
C10 REVEGETATION PLAN